

Work Package 4.1

The aim of this workpackage was to develop a multipurpose installation for fine chemicals that will consist of plug-in microstructured reactors and separators for different liquid-liquid systems. As a model reaction, the highly exothermic cyclisation of pseudoionone (PI) to β -ionone was chosen. The first generation reactors (WP3) are developed using the reaction kinetics of cyclisation and isomerisation investigated in WP2. The experiments are in progress to evaluate the influence of flow rates upon the flow regime, mass/heat transfer characteristics, reactor performance and product yield and selectivity for different systems. The experimental data obtained will be used to validate and/or refine the models elaborated in WP2, and to ameliorate and modify eventually the reactors (WP3).

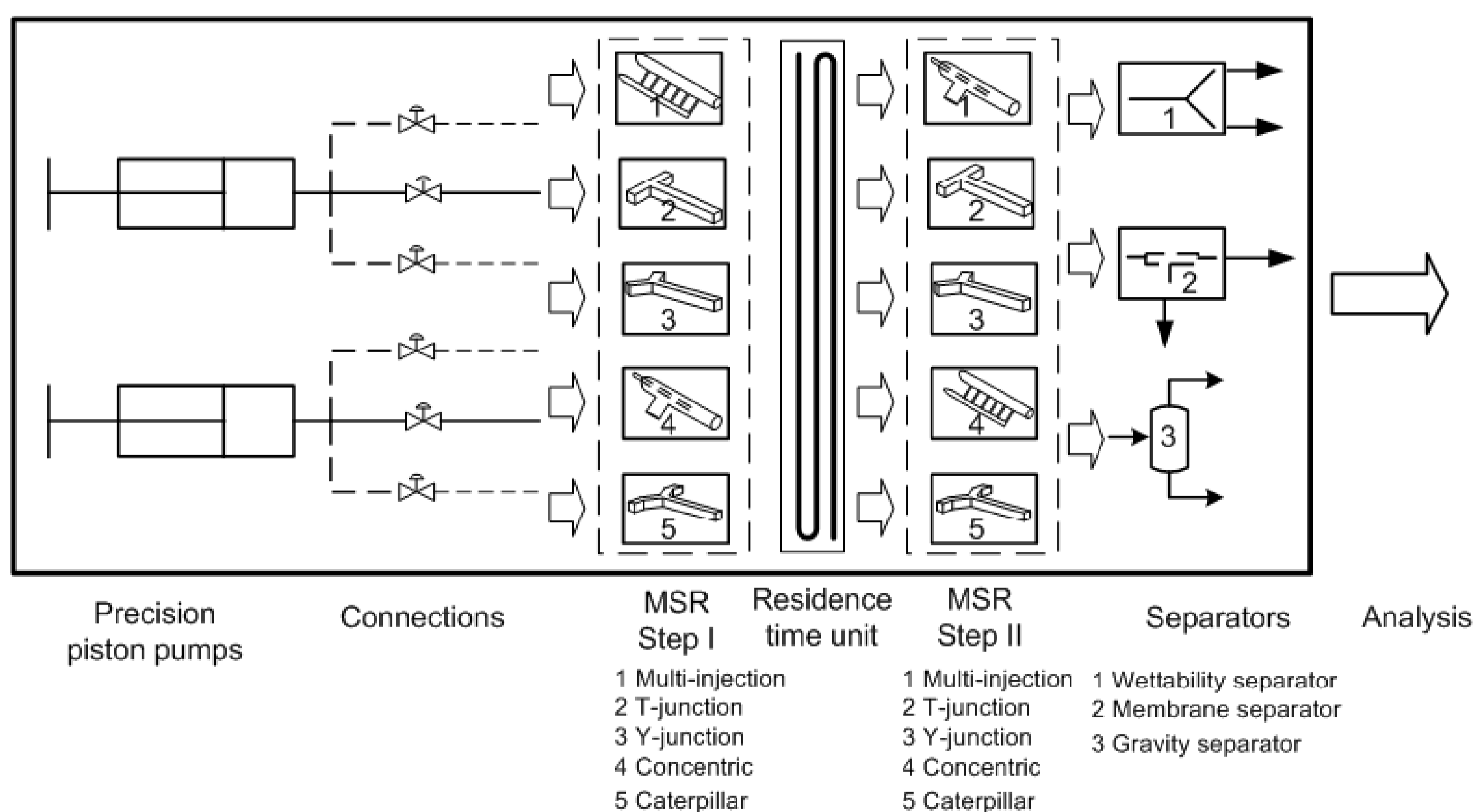
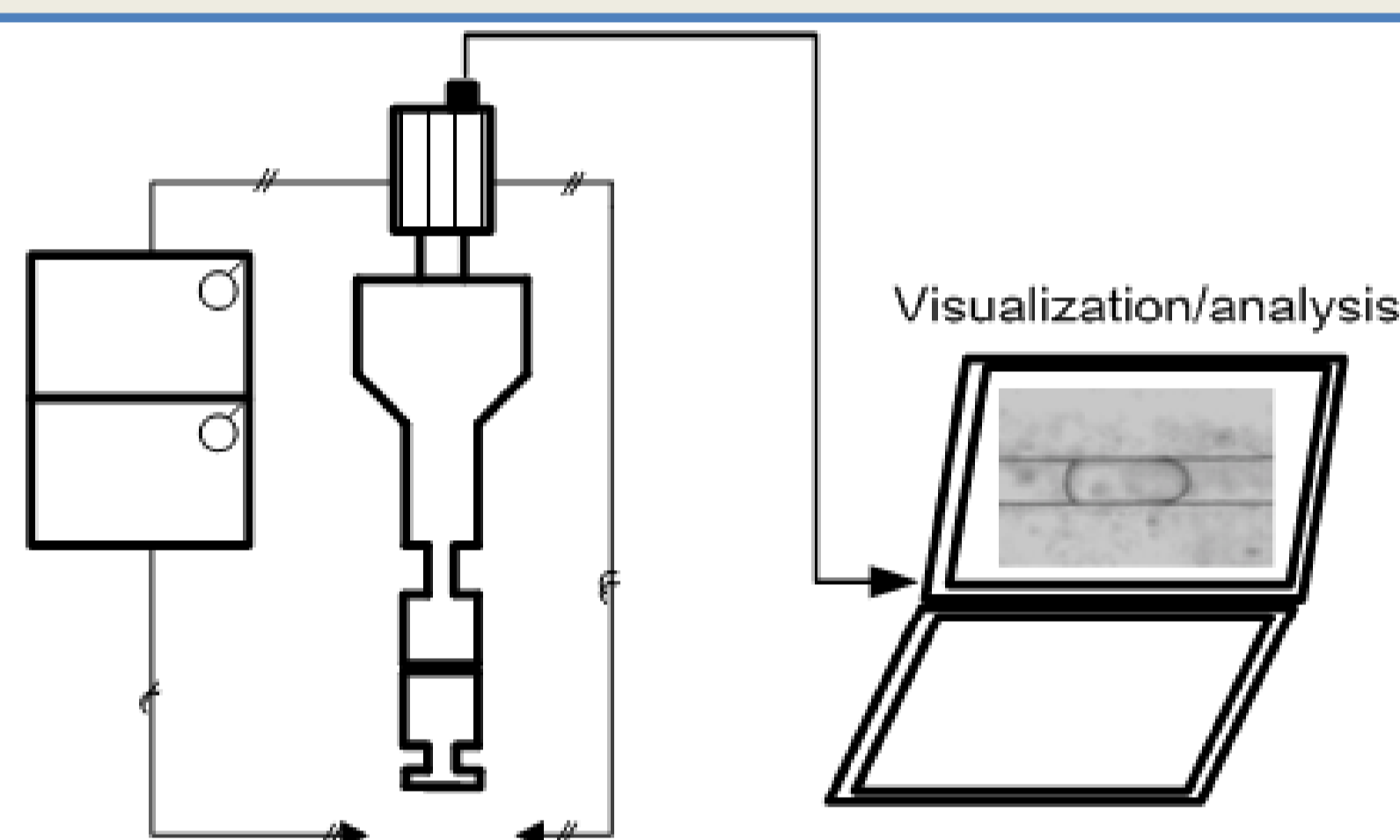

Task 4A.1 : Development and characterization of multipurpose devices

- Development of general criteria based on the knowledge obtained from experimental and computational studies for the development of different modules for multipurpose plant
- Investigation of heat and mass transfer, reactor performance and product yield and selectivity for different systems
- Carry out experiments and simulations for different liquid-liquid systems
- Development of flow splitters for different liquid-liquid systems

Characteristics of multipurpose plant

- Continuously operating high precision piston pumps
- Equipments placed on a support plate
- Provision to fix equipment at any place on the plate
- Movable camera
- Easy to expand for multistep synthesis
- Supply of heating/cooling fluid
- Inert air supply in case required to flush
- Variable throughput
- A new plant concept in chemical processing

Task 4B.1: Study of cyclisation reaction using multipurpose plant

- Process analysis and product control (GIV)
- Optimization of the multipurpose plant (GIV)
- Investigation of heat and mass transfer, reactor performance and product yield and selectivity for cyclisation reaction (EPF)
- Validation of modeling results obtained in WP2 (EPF)
- Technical support for the integration of reactor and separator in the multipurpose plant (IMM)

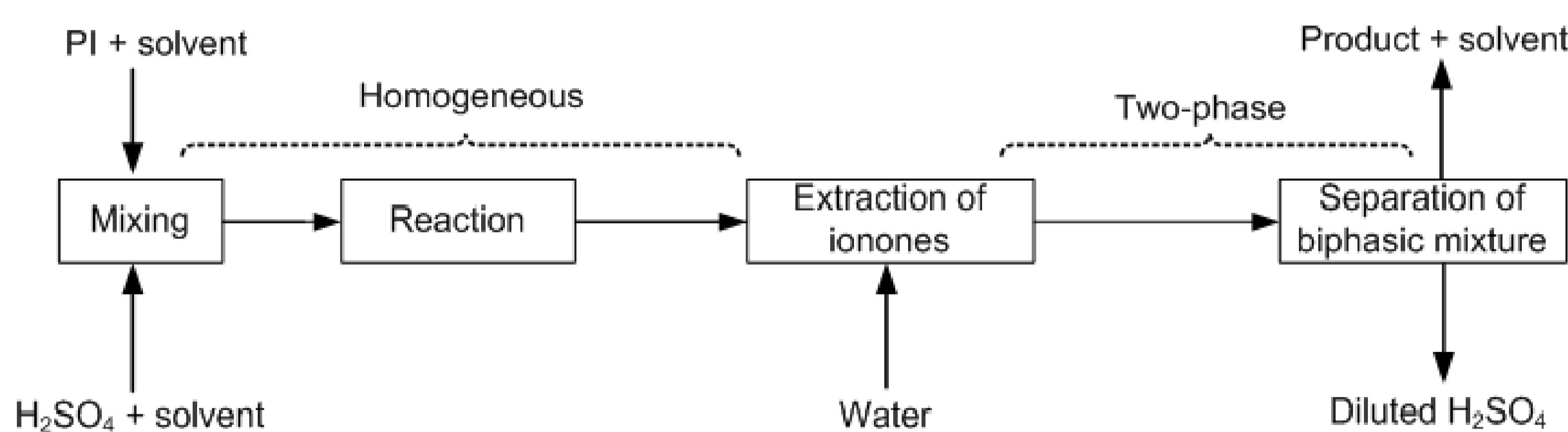

Model process: (Pseudoionone cyclisation)

Mixing: Mixing with efficient heat removal → mixing in microstructured reactors

Reaction: Kinetics essential → intrinsic kinetics using batch/microstructured reactors

Extraction of ionone: Extraction with efficient heat removal → mass transfer in microstructured reactors

Separation of biphasic mixture: Flow splitting → microstructured flow separators